

S1722DR8



S1722DR8

High-Performance 167 Channel GNSS Receiver with Dead Reckoning

Features

- 100% coverage
- Continuous position fix in tunnels
- Automatic sensor calibration
- 167 Channel C/A Code
- GPS / QZSS / SBAS and GLONASS or Beidou
- Perform 16 million time-frequency hypothesis testing per second
- Open sky hot start 1 sec
- Open sky cold start 29 sec
- Cold start sensitivity -148dBm
- Tracking sensitivity -165dBm
- Accuracy 2.5m CEP
- Operating temperature -40 ~ +85°C
- RoHS compliant

Applications

- Automotive Navigation

The S1722DR8 GNSS Dead-Reckoning receiver module combines GNSS position data, gyroscope data (measuring turning angle), and odometer data (measuring distance traveled) to formulate position solution. This enables accurate navigation solution in poor signal environment or signal blocked area such as inside tunnels. The S1722DR8 is ideal for applications requiring accurate continuous navigation with 100% availability.

The Extended Kalman Filter algorithm combines GNSS and sensor data with weighting function dependent on GNSS signal quality. In poor signal reception area and multipath environment, the position error is reduced by dead reckoning.

The S1722DR8 features 167 channel GNSS receiver with fast time to first fix and improved -148dBm cold start sensitivity. The superior cold start sensitivity allows it to acquire, track, and get position fix autonomously in difficult weak signal environment. The receiver's -165dBm tracking sensitivity allows continuous position coverage in nearly all application environments. The high performance search engine is capable of testing 16,000,000 time-frequency hypotheses per second, offering industry-leading signal acquisition and TTFF speed.

The receiver is suitable for in vehicle car navigation system that requires high performance continuous navigation, low power, and low cost.

TECHNICAL SPECIFICATIONS

Receiver Type	167-channel Venus 8 engine L1 GPS/QZSS/SBAS, L1 GLONASS or B1 Beidou C/A code
Accuracy	Position 2.5m CEP Velocity 0.1m/sec Time 10ns
Startup Time	1 second hot start under open sky 28 second warm-start under open sky (average) 29 second cold-start under open sky (average)
Reacquisition	1s
Sensitivity	-148dBm cold start -165dBm tracking
Update Rate	1Hz
Operational Limits	Altitude < 18,000m or velocity < 515m/s
Serial Interface	3.3V LVTTTL level
Protocol	NMEA-0183 V3.01 SkyTraq Binary 38400 baud, 8, N, 1
Datum	Default WGS-84 User definable
Input Voltage	3.3V+/- 10%
Input Current	64mA acquisition 55mA tracking
Dimension	17mm L x 22.4mm W
Weight:	2g
Operating Temperature	-40°C ~ +85°C
Storage Temperature	-55 ~ +100°C
Humidity	5% ~ 95%

BLOCK DIAGRAM

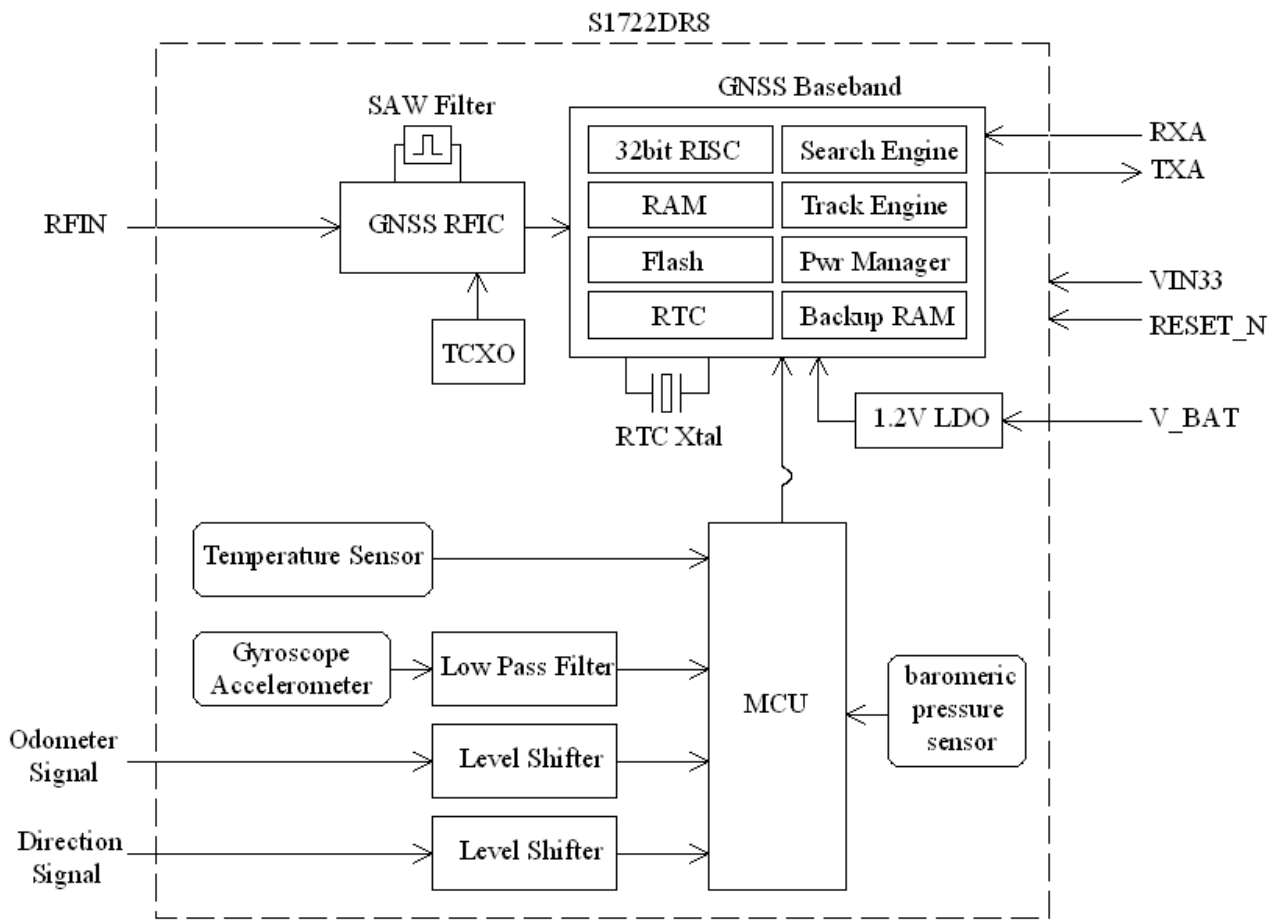

Module block schematic

INTERFACE

15	A GND	SCL	14
16	R FIN	SDA	13
17	A GND	BOOT_SEL_S	12
18	BOOT_SEL_M	VBAT	11
19	VCC33	RESET_N	10
20	MOSI	VCC33	9
S1722DR8			
21	MISO	GPIO6	8
22	P1PPS	GND	7
23	SPI_CLK	VCC33	6
24	SPI_CSN	TXB	5
25	RXA	RXB	4
26	TXA	LED	3
27	ODOMETER	GND	2
28	GND	DIRECTION	1

PINOUT DESCRIPTION

Pin No.	Name	Description
1	DIRECTION	Forward or reverse direction input from vehicle. Reverse (HIGH > 2.0V), Forward (LOW < 0.8V), max input 36V
2	GND	Ground
3	LED	GPS fix indicator. Output low at initial no fix, toggle each second after position fix.
4	RXB	UART2 serial data input, 3.3V LVTTL
5	TXB	UART2 serial data output, 3.3V LVTTL
6	VCC33	Main 3.3V DC supply input
7	GND	Digital ground
8	GPIO6	GPIO6 (reserved).
9	VCC33	Main 3.3V DC supply input
10	RESET_N	External reset (active low). Can be left unconnected if unused.
11	VBAT	Backup supply voltage for internal RTC and backup SRAM, 2.5V ~ 3.6V. VBAT must be applied whenever VCC33 is applied. This pin should be powered continuously to minimize the startup time. If VCC33 and VBAT are both removed, the receiver will be in factory default mode upon power up, all user configuration set is lost. For applications the does not care cold starting every time, this pin can be connect to VCC33.
12	BOOT_SEL_S	No connection for normal use. Pull-low for loading firmware into empty or corrupted Flash memory from ROM mode for the master processor.
13	SDA	2-wire interface data line (reserved)
14	SCL	2-wire interface clock line (reserved)
15	GNDA	RF ground
16	RFIN	RF input with 3.3V active antenna bias voltage

17	GNDA	RF ground
18	BOOT_SEL_M	No connection for normal use. Pull-low for loading firmware into empty or corrupted Flash memory from ROM mode for the master processor.
19	VCC33	Main 3.3V DC supply input
20	MOSI	SPI master output slave input (reserved)
21	MISO	SPI master input slave output (reserved)
22	1PPS	One-pulse-per-second (1PPS) time mark output, 3V LVTTTL. The rising edge synchronized to UTC second when getting 3D position fix. The pulse duration is about 800usec at rate of 1 Hz.
23	SPI_CLK	SPI clock (reserved)
24	SPI_CSN	SPI chip select (reserved)
25	RXA	UART1 serial data input, 3.3V LVTTTL. This UART input is normally for sending commands or information to the receiver in SkyTraq binary protocol. In the idle condition, this pin should be driven HIGH. If the driving circuitry is powered independently of S1722DR8, ensure that this pin is not driven to HIGH when primary power to S1722DR8 is removed.
26	TXA	UART1 serial data output, 3.3V LVTTTL. This UART output is normally used for sending position, time and velocity information from the receiver in NMEA-0183 format. When idle, this pin output HIGH.
27	ODOMETER	Car speed pulse input, frequency < 4kHz. LOW < 0.8V, HIGH > 2.0V, max input 36V.
28	GND	Ground

MECHANICAL DIMENSION

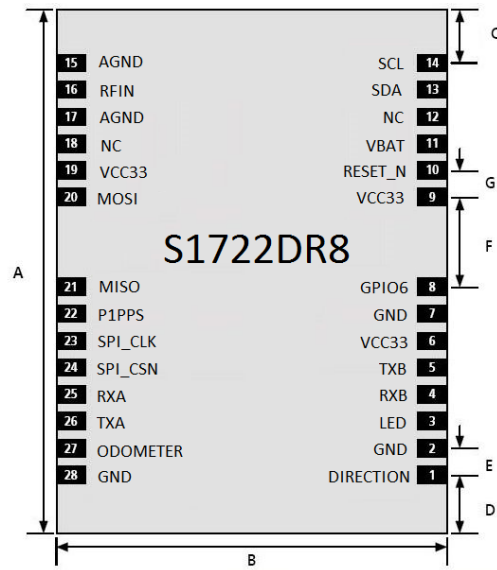

A	22.4mm
B	17.0mm
C	2.85mm
D	2.55mm
E	1.1mm
F	3.8mm
G	1.1mm

RECOMMENDED PAD LAYOUT

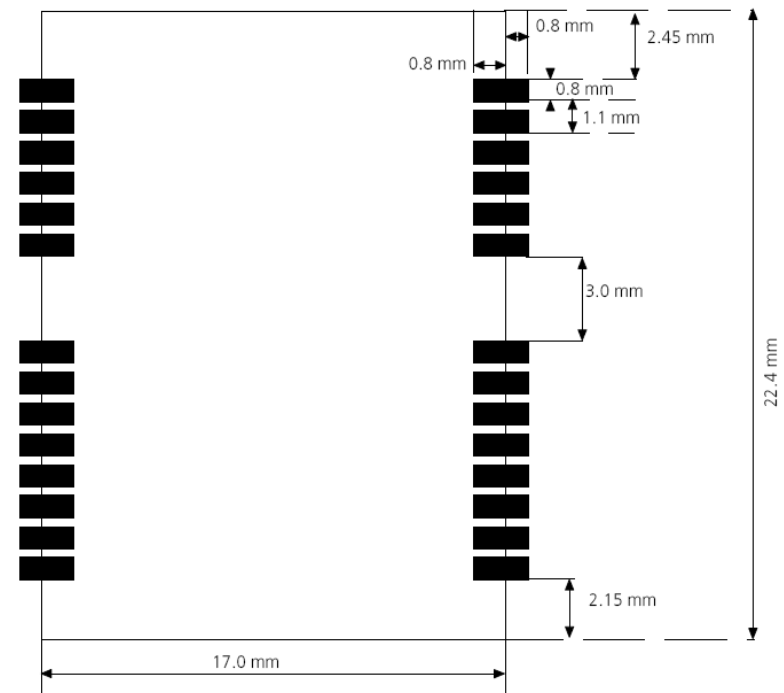

ELECTRICAL SPECIFICATIONS

ABSOLUTE MAXIMUM RATINGS

Parameter	Minimum	Maximum	Condition
Supply Voltage (VCC33)	-0.5	3.6	Volt
Backup Battery Voltage (VBAT)	-0.5	3.6	Volt
Input Pin Voltage	-0.5	VCC33+0.5	Volt
Input Power at RFIN		+5	dBm
Storage Temperature	-55	+100	degC

OPERATING CONDITIONS

Parameter	Min	Typ	Max	Unit
Supply Voltage (VCC33)	3.0	3.3	3.6	Volt
Acquisition Current (exclude active antenna current)		64		mA
Tracking Current (exclude active antenna current)		55		mA
Backup Voltage (VBAT)	2.5		3.6	Volt
Backup Current (VCC33 voltage applied)			1.5	mA
Backup Current (VCC33 voltage off)			35	uA
Output Low Voltage			0.4	Volt
Output HIGH Voltage	2.4			Volt
Input LOW Voltage			0.8	Volt
Input HIGH Voltage	2			Volt
Input LOW Current	-10		10	uA
Input HIGH Current	-10		10	uA
RF Input Impedance (RFIN)		50		Ohm

POWER SUPPLY REQUIREMENT

S1722DR8 requires a stable power supply, avoid ripple on VCC33 pin (<50mVpp). Power supply noise can affect the receiver's sensitivity. Bypass capacitors should be placed close to the module VCC33 pin, with values adjusted depending on the amount and type of noise present on the supply line.

BACKUP SUPPLY

The purpose of backup supply voltage pin (VBAT) is to keep the SRAM memory and the RTC powered when the module is powered down. This enables the module to have a faster time-to-first-fix when the module is powered on again. DR calibration data is also kept in this SRAM. If VBAT is not maintained when main power is removed, the receiver will need to go through auto calibration process before DR could take effect every time it's powered on. The backup current drain is less than 35 μ A. In normal powered on state, the internal processor access the SRAM and current drain is higher in active mode

ANTENNA CONSIDERATION

3.3V GPS/GLONASS or GPS/Beidou active antenna with 15dB ~ 28dB gain and noise figure less than 2dB can be used for better performance. GPS antenna will also work.

CALIBRATION of DR

S1722DR8 performs calibration of gyro bias and odometer scale automatically using GPS. Customer is not required to perform calibration at installation.

For product testing or benchmarking, the following procedure steps can achieve efficient calibration quickly after a short period of time:

1. Find a open sky place.
2. Start S1722DR8 and stand still for 60 seconds until position fix is achieved.
3. Drive straight for 500m at speed of at least 40km/hr.
4. For next 3 minutes, drive straight and make at least 360-deg turns (either two 90-degrees left turns and right turns, or four left turns, or four right turns) then drive straight for at least another 300m.

APPLICATION CIRCUIT

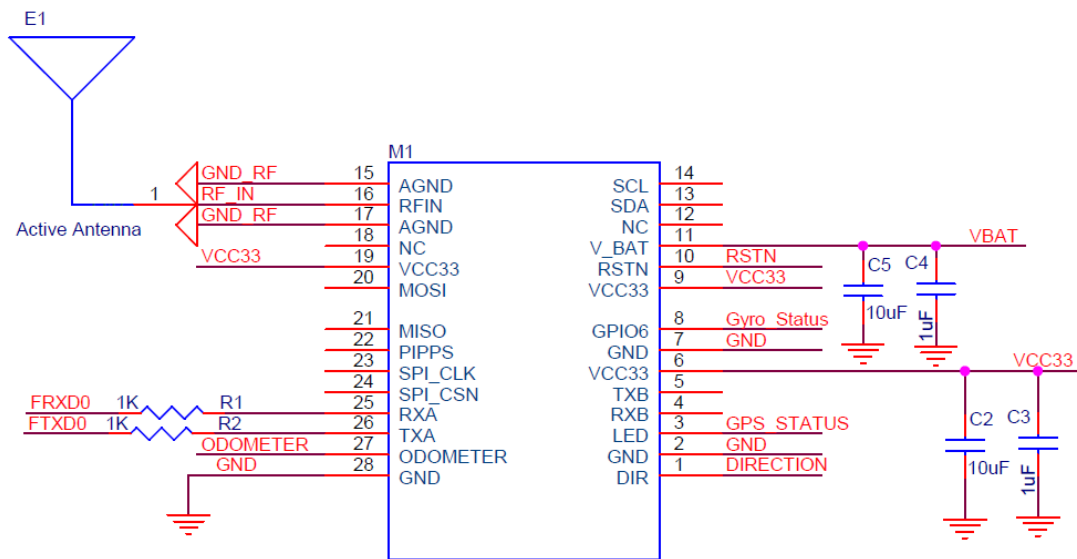

There are already LM393-based level shifters within the S1722DR8 module, the odometer and forward/reverse signal can be directly applied to the module.

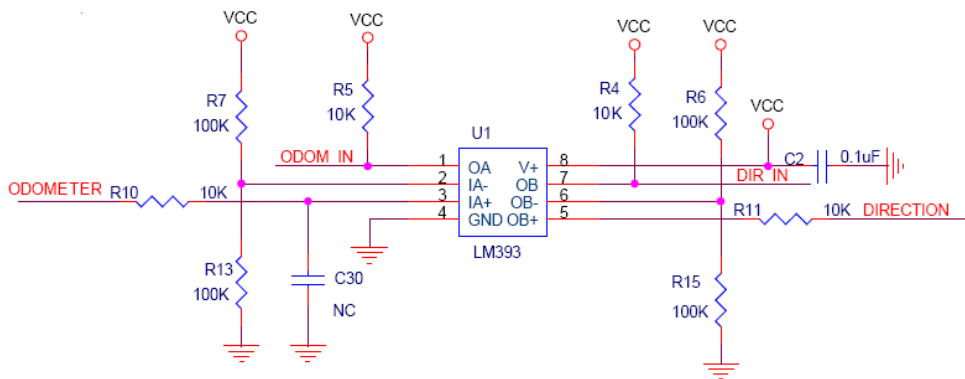

For applications that has no forward/reverse indication signal, simply ground the forward/reverse direction input.

For application that has forward/reverse direction inverted, opto-coupler interface shown below may be used. Or can also contact distributor or SkyTraq for a firmware version interpreting the direction indication signal inverted.

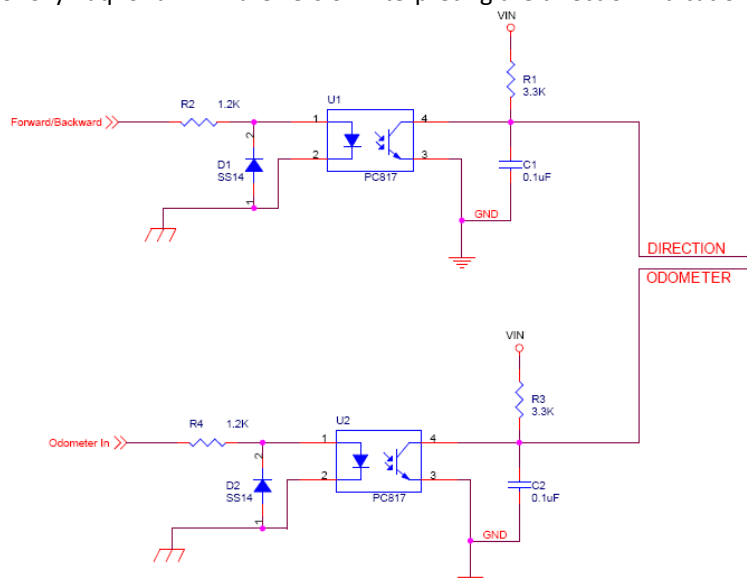

NMEA Output Description

The output protocol supports NMEA-0183 standard. The implemented messages include GGA, GLL, GSA, GSV, VTG, RMC, ZDA and GNS messages. The NMEA message output has the following sentence structure:

\$aacc,c-c*hh<CR><LF>

The detail of the sentence structure is explained in Table 1.

Table 1: The NMEA sentence structure

character	HEX	Description
"\$"	24	<u>Start of sentence.</u>
Aacc		<u>Address field.</u> "aa" is the talker identifier. "ccc" identifies the sentence type.
","	2C	<u>Field delimiter.</u>
c-c		<u>Data sentence block.</u>
"*"	2A	<u>Checksum delimiter.</u>
Hh		<u>Checksum field.</u>
<CR><LF>	0D0A	<u>Ending of sentence.</u> (carriage return, line feed)

Table 2: Overview of SkyTraq receiver's NMEA messages for S1722DR8P-BD GPS/Beidou DR Receiver

\$GNGGA	Time, position, and fix related data of the receiver.
\$GNGLL	Position, time and fix status.
\$GNGSA \$GPGSA \$BDGSA	Used to represent the ID's of satellites which are used for position fix. When both GPS and Beidou satellites are used in position solution, a \$GNGSA sentence is used for GPS satellites and another \$GNGSA sentence is used for Beidou satellites. When only GPS satellites are used for position fix, a single \$GPGSA sentence is output. When only Beidou satellites are used, a single \$BDGSA sentence is output.
\$GPGSV \$BDGSV	Satellite information about elevation, azimuth and CNR, \$GPGSV is used for GPS satellites, while \$BDGSV is used for Beidou satellites
\$GNRMC	Time, date, position, course and speed data.
\$GNVTG	Course and speed relative to the ground.
\$GNZDA	UTC, day, month and year and time zone.

Table 3: Overview of SkyTraq receiver's NMEA messages for S1722DR8P-GL GPS/GLONASS DR Receiver

\$GNGGA	Time, position, and fix related data of the receiver.
\$GNGLL	Position, time and fix status.
\$GNGSA \$GPGSA \$GLGSA	Used to represent the ID's of satellites which are used for position fix. When both GPS and GLONASS satellites are used in position solution, a \$GNGSA sentence is used for GPS satellites and another \$GNGSA sentence is used for GLONASS satellites. When only GPS satellites are used for position fix, a single \$GPGSA sentence is output. When only GLONASS satellites are used, a single \$GLGSA sentence is output.
\$GPGSV \$GLGSV	Satellite information about elevation, azimuth and CNR, \$GPGSV is used for GPS satellites, while \$GLGSV is used for GLONASS satellites
\$GNRMC	Time, date, position, course and speed data.
\$GNVTG	Course and speed relative to the ground.
\$GNZDA	UTC, day, month and year and time zone.

The formats of the supported NMEA messages are described as follows:

GGA - Global Positioning System Fix Data

Time, position and fix related data for a GPS receiver.

Structure:

\$GPGGA,hhmmss.sss,ddmm.mmmm,a,dddmm.mmmm,a,x,xx,x.x,x.x,M,,,,,xxxx*hh<CR><LF>
 1 2 3 4 5 6 7 8 9 10 11

Example:

\$GPGGA,111636.932,2447.0949,N,12100.5223,E,1,11,0.8,118.2,M,,,,,0000*02<CR><LF>

Field	Name	Example	Description
1	UTC Time	111636.932	UTC of position in hhmmss.sss format, (000000.000 ~ 235959.999)
2	Latitude	2447.0949	Latitude in ddmm.mmmm format Leading zeros transmitted
3	N/S Indicator	N	Latitude hemisphere indicator, 'N' = North, 'S' = South
4	Longitude	12100.5223	Longitude in dddmm.mmmm format Leading zeros transmitted
5	E/W Indicator	E	Longitude hemisphere indicator, 'E' = East, 'W' = West
6	GPS quality indicator	1	GPS quality indicator 0: position fix unavailable 1: valid position fix, SPS mode 2: valid position fix, differential GPS mode 3: GPS PPS Mode, fix valid 4: Real Time Kinematic. System used in RTK mode with fixed integers 5: Float RTK. Satellite system used in RTK mode. Floating integers 6: Estimated (dead reckoning) Mode 7: Manual Input Mode 8: Simulator Mode
7	Satellites Used	11	Number of satellites in use, (00 ~ 12)
8	HDOP	0.8	Horizontal dilution of precision, (00.0 ~ 99.9)
9	Altitude	108.2	mean sea level (geoid), (-9999.9 ~ 17999.9)
10	DGPS Station ID	0000	Differential reference station ID, 0000 ~ 1023 NULL when DGPS not used
11	Checksum	02	

GLL – Latitude/Longitude

Latitude and longitude of current position, time, and status.

Structure:

\$GPGLL,ddmm.mmmm,a,dddmm.mmmm,a,hhmmss.sss,A,a*hh<CR><LF>
 1 2 3 4 5 6 7 8

Example:

\$GPGLL,2447.0944,N,12100.5213,E,112609.932,A,A*57<CR><LF>

Field	Name	Example	Description
1	Latitude	2447.0944	Latitude in ddmm.mmmm format Leading zeros transmitted
2	N/S Indicator	N	Latitude hemisphere indicator 'N' = North 'S' = South
3	Longitude	12100.5213	Longitude in dddmm.mmmm format Leading zeros transmitted
4	E/W Indicator	E	Longitude hemisphere indicator 'E' = East 'W' = West
5	UTC Time	112609.932	UTC time in hhmmss.sss format (000000.000 ~ 235959.999)
6	Status	A	Status, 'A' = Data valid, 'V' = Data not valid
7	Mode Indicator	A	Mode indicator 'N' = Data not valid 'A' = Autonomous mode 'D' = Differential mode 'E' = Estimated (dead reckoning) mode 'M' = Manual input mode 'S' = Simulator mode
8	Checksum	57	

GSA – GNSS DOP and Active Satellites

GPS receiver operating mode, satellites used in the navigation solution reported by the GGA or GNS sentence and DOP values.

Structure:

```
$GPGSA,A,x,xx,xx,xx,xx,xx,xx,xx,xx,xx,xx,xx,xx,x.x,x.x,x.x*hh<CR><LF>
  1 2 3 3 3 3 3 3 3 3 3 3 3 4 5 6 7
```

Example:

```
$GPGSA,A,3,05,12,21,22,30,09,18,06,14,01,31,,1.2,0.8,0.9*36<CR><LF>
```

Field	Name	Example	Description
1	Mode	A	Mode 'M' = Manual, forced to operate in 2D or 3D mode 'A' = Automatic, allowed to automatically switch 2D/3D
2	Mode	3	Fix type 1 = Fix not available 2 = 2D 3 = 3D
3	Satellite used 1~12	05,12,21,22,30,09,18,06,14,01,31,,	01 ~ 32 are for GPS; 33 ~ 64 are for WAAS (PRN minus 87); 65 ~ 96 are for GLONASS (64 plus slot numbers); 193 ~ 197 are for QZSS; 01 ~ 37 are for Beidou (BD PRN). GPS and Beidou satellites are differentiated by the GP and BD prefix. Maximally 12 satellites are included in each GSA sentence.
4	PDOP	1.2	Position dilution of precision (00.0 to 99.9)
5	HDOP	0.8	Horizontal dilution of precision (00.0 to 99.9)
6	VDOP	0.9	Vertical dilution of precision (00.0 to 99.9)
7	Checksum	36	

GSV – GNSS Satellites in View

Number of satellites (SV) in view, satellite ID numbers, elevation, azimuth, and SNR value. Four satellites maximum per transmission.

Structure:

```
$GPGSV,x,x,xx,xx,xx,xxx,xx,...,xx,xx,xxx,xx *hh<CR><LF>
    1 2 3 4 5 6 7 4 5 6 7 8
```

Example:

```
$GPGSV,3,1,12,05,54,069,45,12,44,061,44,21,07,184,46,22,78,289,47*72<CR><LF>
$GPGSV,3,2,12,30,65,118,45,09,12,047,37,18,62,157,47,06,08,144,45*7C<CR><LF>
$GPGSV,3,3,12,14,39,330,42,01,06,299,38,31,30,256,44,32,36,320,47*7B<CR><LF>
```

Field	Name	Example	Description
1	Number of message	3	Total number of GSV messages to be transmitted (1-3)
2	Sequence number	1	Sequence number of current GSV message
3	Satellites in view	12	Total number of satellites in view (00 ~ 12)
4	Satellite ID	05	01 ~ 32 are for GPS; 33 ~ 64 are for WAAS (PRN minus 87); 65 ~ 96 are for GLONASS (64 plus slot numbers); 193 ~ 197 are for QZSS; 01 ~ 37 are for Beidou (BD PRN). GPS and Beidou satellites are differentiated by the GP and BD prefix. Maximally 4 satellites are included in each GSV sentence.
5	Elevation	54	Satellite elevation in degrees, (00 ~ 90)
6	Azimuth	069	Satellite azimuth angle in degrees, (000 ~ 359)
7	SNR	45	C/No in dB (00 ~ 99) Null when not tracking
8	Checksum	72	

RMC – Recommended Minimum Specific GNSS Data

Time, date, position, course and speed data provided by a GNSS navigation receiver.

Structure:

\$GPRMC,hhmmss.sss,A,dddmm.mmmm,a,dddmm.mmmm,a,x.x,x.x,ddmmyy,,,a*hh<CR><LF>
 1 2 3 4 5 6 7 8 9 10 11

Example:

\$GPRMC,111636.932,A,2447.0949,N,12100.5223,E,000.0,000.0,030407,,,A*61<CR><LF>

Field	Name	Example	Description
1	UTC time	0111636.932	UTC time in hhmmss.sss format (000000.000 ~ 235959.999)
2	Status	A	Status 'V' = Navigation receiver warning 'A' = Data Valid
3	Latitude	2447.0949	Latitude in dddmm.mmmm format Leading zeros transmitted
4	N/S indicator	N	Latitude hemisphere indicator 'N' = North 'S' = South
5	Longitude	12100.5223	Longitude in dddmm.mmmm format Leading zeros transmitted
6	E/W Indicator	E	Longitude hemisphere indicator 'E' = East 'W' = West
7	Speed over ground	000.0	Speed over ground in knots (000.0 ~ 999.9)
8	Course over ground	000.0	Course over ground in degrees (000.0 ~ 359.9)
9	UTC Date	030407	UTC date of position fix, ddmmyy format
10	Mode indicator	A	Mode indicator 'N' = Data not valid 'A' = Autonomous mode 'D' = Differential mode 'E' = Estimated (dead reckoning) mode 'M' = Manual input mode 'S' = Simulator mode
11	checksum	61	

VTG – Course Over Ground and Ground Speed

The Actual course and speed relative to the ground.

Structure:

GPVTG,x.x,T,,M,x.x,N,x.x,K,a*hh<CR><LF>
1 2 3 4 5

Example:

\$GPVTG, 000.0,T,,M,000.0,N,0000.0,K,A*3D<CR><LF>

Field	Name	Example	Description
1	Course	000.0	True course over ground in degrees (000.0 ~ 359.9)
2	Speed	000.0	Speed over ground in knots (000.0 ~ 999.9)
3	Speed	0000.0	Speed over ground in kilometers per hour (0000.0 ~ 1800.0)
4	Mode	A	Mode indicator 'N' = not valid 'A' = Autonomous mode 'D' = Differential mode 'E' = Estimated (dead reckoning) mode 'M' = Manual input mode 'S' = Simulator mode
5	Checksum	3D	

STI,20 Dead Reckoning Status message

Structure:

PSTI,xx,x,x,x,xx,x,x,x,xxx.xx,xx.xx,xx.xx,x.xx*xx<CR><LF>
 1 2 3 4 5 6 7 8 9 10 11 12 13

Example:

\$PSTI,20,1,1,1,32,A,0,1,821.95,20.73,-13.45,6.63*40<CR><LF>

Field No.	Example	Format	Unit	Description
1	20	numeric	-	Proprietary message identifier: 20
2	1	numeric	-	Odometer Calibrate Status 1: calibrated 0: not calibrated
3	1	numeric	-	Gyro and Accelerometer Calibrate Status 1: calibrated 0: not calibrated
4	1	numeric	-	Sensor input available 1: available 0: not available
5	32	numeric	Pulse	Odometer pulse count
6	A	character	-	Position Mode indicator: A=GPS fix, N = Data not valid, E = Estimated(dead reckoning) mode
7	0	numeric	-	Backward Status 1: activated, moving backward 0: normal, moving forward
8	1	numeric	-	Antenna detecting(Reserved) 1: antenna available 0: antenna not available
9	821.95	numeric	0.002V	Gyro Bias
10	20.73	numeric	cm/pulse	Odometer Scaling Factor
11	-13.45	numeric	Deg/sec	Rotation rate
12	6.63	numeric	m	Distance
13	40	hexadecimal	-	Checksum

ORDERING INFORMATION

Model Name	Description
S1722DR8P-BD	GPS/Beidou Dead Reckoning Receiver Module, with pressure sensor
S1722DR8P-GL	GPS/GLONASS Dead Reckoning Receiver Module, with pressure sensor

The information provided is believed to be accurate and reliable. These materials are provided to customers and may be used for informational purposes only. No responsibility is assumed for errors or omissions in these materials, or for its use. Changes to specification can occur at any time without notice.

These materials are provided "as is" without warranty of any kind, either expressed or implied, relating to sale and/or use including liability or warranties relating to fitness for a particular purpose, consequential or incidental damages, merchantability, or infringement of any patent, copyright or other intellectual property right. No warrant on the accuracy or completeness of the information, text, graphics or other items contained within these materials. No liability assumed for any special, indirect, incidental, or consequential damages, including without limitation, lost revenues or lost profits, which may result from the use of these materials.

The product is not intended for use in medical, life-support devices, or applications involving potential risk of death, personal injury, or severe property damage in case of failure of the product.

Change Log

Version 0.2, August 25, 2016

1. Updated table 2 and table 3 NMEA Output Description
2. Added S1722DR8P-GL order information

Version 0.1, April 22, 2016

1. Initial release